

Main Technical Specification for Marine Anchor Windlass

- Supply capacity: chain diameter 19-150mm, rated load 15.3-860KN
- Control method: local control and remote control
- Can be equipped with drum as an anchoring winch

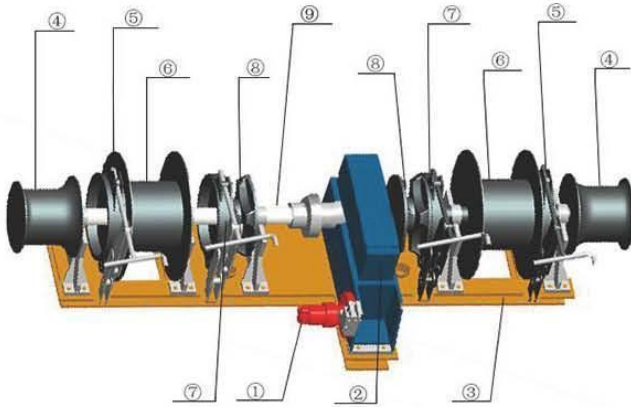

- ① Hydraulic Motor (Electric Motor/Disel Motor)
- ② Gearbox
- ③ Pedestal
- ④ Warping End
- ⑤ Drum Brake
- ⑥ Drum
- ⑦ Gypsy Wheel Brake
- ⑧ Gypsy Wheel
- ⑨ Shaft

Technical Specifications

Chain dia. mm	Chain grade AM	Rated load kN	Rated speed m/min	Rope dia. mm	Rope length m	Mooring speed m/min	motor power kW
Φ 58/60/62	3	159.8/171/182.6	≥9	Φ 60	200	≥15	55
Φ 64/66/68	3	194.6/206.9/219.6	≥9	Φ 60	200	≥15	75
Φ 64/66/68	3	194.6/206.9/219.6	≥9	Φ 65	200	≥15	75
Φ 64/66/68	3	194.6/206.9/219.6	≥9	Φ 70	200	≥15	75
Φ 70/73	3	232.8/253.1	≥9	Φ 60	200	≥15	86
Φ 70/73	3	232.8/253.1	≥9	Φ 65	200	≥15	86
Φ 70/73	3	232.8/253.1	≥9	Φ 70	200	≥15	86
Φ 76/78	3	274.4/289	≥9	Φ 65	200	≥15	95
Φ 76/78	3	274.4/289	≥9	Φ 70	200	≥15	95
Φ 81/84	3	311.6/335.1	≥9	Φ 70	200	≥15	104
Φ 81/84	3	311.6/335.1	≥9	Φ 80	200	≥15	104
Φ 87/90	3	359.5/384.8	≥9	Φ 80	200	≥15	127
Φ 92-100	3	402-475	≥9	Φ 80	200	≥15	152
Φ 102-105	3	494.2/523.7	≥9	Φ 80	200	≥15	184
Φ 107-117	3	543.8-650	≥9	Φ 80	200	≥15	230
Φ 120-132	3	684-827.6	≥9	Φ 80	200	≥15	288

Note:

1. Driving type: manual type ,electric motor,hydraulic motor or diesel engine.
2. Double gypsy wheels or single gypsy wheel
3. Double warping ends or single warping end

Above specifications only for reference, we can supply various windlasses according to your requirements.